

Technical data sheet

Product features



STEAMBOX gas convection oven 6x GN 1/1 boiler Color touch screen Automatic cleaning 10" display

Model	SAP Code	00038548
STMB 0611 G	A group of articles - web	Convection machines



- Number of GN / EN: 6
- GN / EN size in device: GN 1/1
- GN device depth: 65
- Control type: Touchscreen
- Display size: 10"
- Humidity control: MeteoSystem - regulation based on direct measurement of humidity in the chamber (patented)
- Advanced moisture adjustment: Steamtuner - 5-stage system of setting steam saturation by controlled combination of production by boiler or injection
- Delta T heat preparation: Yes
- Automatic preheating: Yes
- Multi level cooking: Drawer program - control of heat treatment for each dish separately
- Door constitution: Odvětrávané bezpečnostní trojitě sklo, rozebiratelné pro snadné čištění

SAP Code	00038548	Power gas [kW]	12.000
Net Width [mm]	860	Type of gas	Natural Gas
Net Depth [mm]	795	Number of GN / EN	6
Net Height [mm]	835	GN / EN size in device	GN 1/1
Net Weight [kg]	135.00	GN device depth	65
Power electric [kW]	0.400	Control type	Touchscreen
Loading	230 V / 1N - 50 Hz	Display size	10"

Technical data sheet

Technical drawing



STEAMBOX gas convection oven 6x GN 1/1 boiler Color touch screen Automatic cleaning 10" display

Model	SAP Code	00038548
STMB 0611 G	A group of articles - web	Convection machines

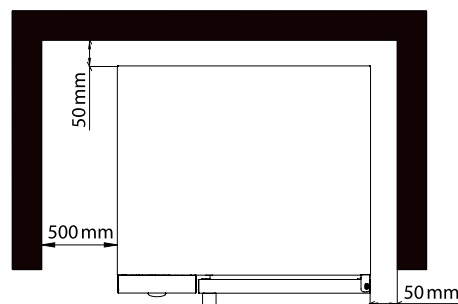
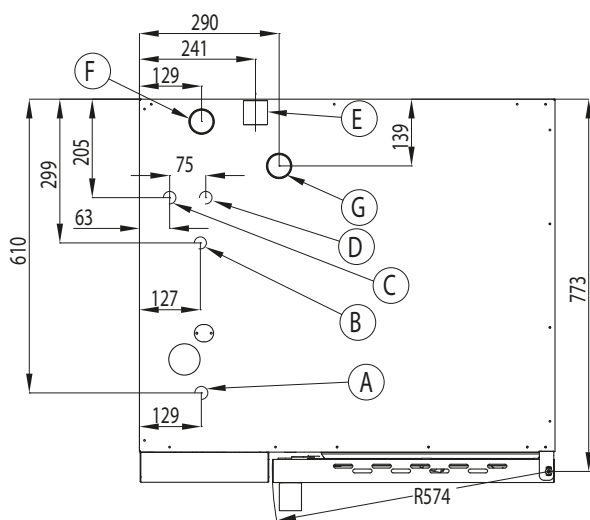
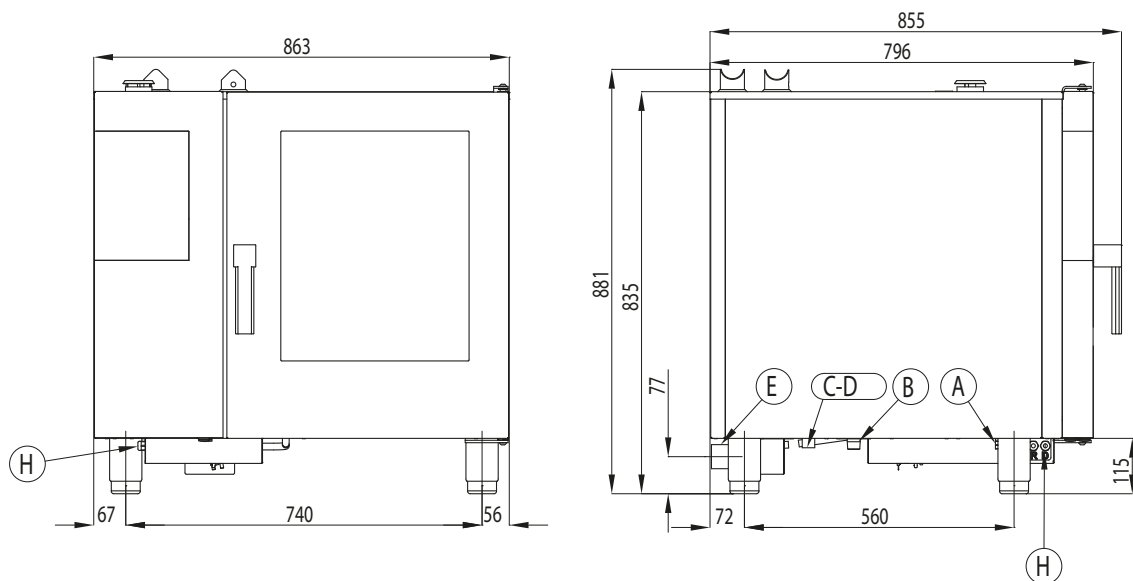

* Clearance requirements

NOTE

* Drain line must be vented

Technical data sheet

Product benefits



STEAMBOX gas convection oven 6x GN 1/1 boiler Color touch screen Automatic cleaning 10" display

Model	SAP Code	00038548
STMB 0611 G	A group of articles - web	Convection machines

1

Triple glass door as standard

better thermal insulation, less frequent reheating, safer operation due to lower outer glass temperature, less radiant heat, less heat leakage, lower load on electronics and mechanical parts

- reduction of heat losses, saving operating costs, reduced risk of injury to the operator when touching the glass, more pleasant working temperature in the kitchen, welcomed especially in the hot summer months, saving operating, service and acquisition costs thanks to the fact that the equipment suffers less from temperature fluctuations and wear

2

Clear 10" touch screen corresponding to other RM line devices

simple intuitive operation using images and visualizations, the same intuitive operation as on other digital devices in the RM line

- saving time when entering programs or cooking itself, saving time when training personnel, when operating the RM line equipment itself, saving costs and time

3

Smart cooking

Predefined basic programs for easy control with just a few touches

- saving human qualifications, time when creating programs

4

Symbiotic steam generation system

simultaneous use of "direct injection" and boiler, maintaining 100% humidity, or its regulation

- preparation of various dishes and cooking styles in an environment precisely set for a given food or dish

5

Self-winding shower

drum reel integrated in the combi oven body the shower is inaccessible after closing the door

- enables pouring food in the convection oven and rinsing the chamber - or speeds up the cooling of the chamber

6

Fan six-speed, reversible with automatic calculation of direction change

in cooperation with the symbiotic system, it ensures perfect distribution of steam without loss of its saturation, its operation is controlled by program or manually

- enables the preparation of various dishes from the most delicate to baking at high temperatures at the highest speeds

7

External temperature probe

temperature probe placed outside the cooking space option to choose from a single or multi-point probe or vacuum probe

- placing it outside the cooking chamber extends its service life
- ensuring complete hygienic safety of dishes
- HACCP recording
- control of heat treatment in the absence chef

8

Longitudinal drawers for GN

drawers placed at the "depth" of the machine option to replace with drawers for 600x400 trays

- possibility to insert the entire GN range, not just the 1/1 size, possibility to use 600x300 baking trays

9

USB

downloading service reports
upgrade software
playback recipes

- quick fault finding
- transfer of original recipes
- maintaining up-to-date software

10

Automatic washing

integrated chamber washing system
option to use liquid and tablet detergents
option to use vinegar as a rinse aid
the system also descales the micro-boiler

- the combi steamer chamber is washed without the presence of the operator, for example overnight
- the system descales the micro-boiler without the need for service intervention
- the chamber is maintained in constant 100% hygienic quality

Technical data sheet

Technical parameters



STEAMBOX gas convection oven 6x GN 1/1 boiler Color touch screen Automatic cleaning 10" display

Model	SAP Code	00038548
STMB 0611 G	A group of articles - web	Convection machines

1. SAP Code:

00038548

2. Net Width [mm]:

860

3. Net Depth [mm]:

795

4. Net Height [mm]:

835

5. Net Weight [kg]:

135.00

6. Gross Width [mm]:

955

7. Gross depth [mm]:

920

8. Gross Height [mm]:

1020

9. Gross Weight [kg]:

156.00

10. Device type:

Combined unit

11. Power electric [kW]:

0.400

12. Loading:

230 V / 1N - 50 Hz

13. Power gas [kW]:

12.000

14. Type of gas:

Natural Gas

15. Material:

AISI 304

16. Exterior color of the device:

Stainless steel

17. Adjustable feet:

Yes

18. Humidity control:

MeteoSystem - regulation based on direct measurement of humidity in the chamber (patented)

19. Stacking availability:

Yes

20. Control type:

Touchscreen

21. Additional information:

Version with left door (hinges on the left, handle on the right)

22. Chimney for moisture extraction:

Yes

23. Delayed start:

Yes

24. Display size:

10"

25. Delta T heat preparation:

Yes

26. Automatic preheating:

Yes

Technical data sheet

Technical parameters



STEAMBOX gas convection oven 6x GN 1/1 boiler Color touch screen Automatic cleaning 10" display

Model	SAP Code	00038548
STMB 0611 G	A group of articles - web	Convection machines

27. Automatic cooling:

Yes

28. Cold smoke-dry function:

Yes

29. Unified finishing of meals EasyService:

Yes

30. Night cooking:

Yes

31. Washing system:

Closed - efficient use of water and washing chemicals by repeated pumping

32. Detergent type:

Liquid washing detergent + liquid rinse aid/vinegar or washing tablets

33. Multi level cooking:

Drawer program - control of heat treatment for each dish separately

34. Advanced moisture adjustment:

Steamtuner - 5-stage system of setting steam saturation by controlled combination of production by boiler or injection

35. Slow cooking:

from 30 °C - the possibility of rising

36. Fan stop:

Immediate when the door is opened

37. Lighting type:

LED lighting in the doors, on both sides

38. Cavity material and shape:

AISI 304, with rounded corners for easy cleaning

39. Reversible fan:

Yes

40. Sustaine box:

Yes

41. Probe:

Yes

42. Shower:

Hand winder

43. Smoke-dry function:

Yes

44. Interior lighting:

Yes

45. Low temperature heat treatment:

Yes

46. Number of fans:

1

47. Number of fan speeds:

6

48. Number of programs:

1000

49. USB port:

Yes, for uploading recipes and updating firmware

50. Door constitution:

Odvětrávané bezpečnostní trojitě sklo, rozebíratelné pro snadné čištění

Technical data sheet

Technical parameters



STEAMBOX gas convection oven 6x GN 1/1 boiler Color touch screen Automatic cleaning 10" display

Model	SAP Code	00038548
STMB 0611 G	A group of articles - web	Convection machines

51. Number of preset programs:

100

52. Number of recipe steps:

9

53. Minimum device temperature [°C]:

30

54. Maximum device temperature [°C]:

300

55. Device heating type:

Combination of steam and hot air

56. HACCP:

Yes

57. Number of GN / EN:

6

58. GN / EN size in device:

GN 1/1

59. GN device depth:

65

60. Food regeneration:

Yes

61. Cross-section of conductors CU [mm²]:

0,5

62. Diameter nominal:

DN 50

63. Water supply connection:

3/4"